

# DRIVE OVER

BELT CONVEYOR

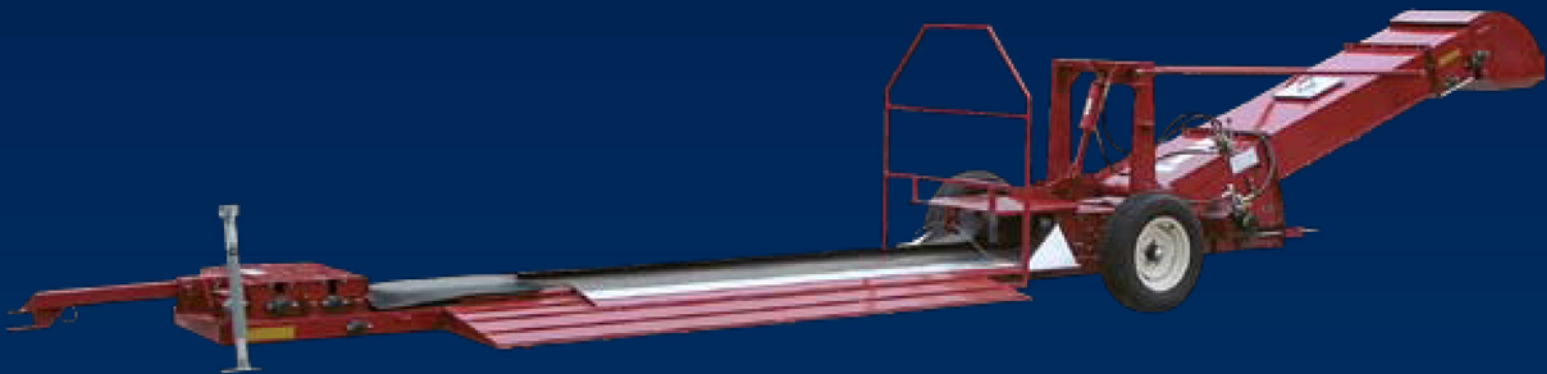

**Capacity — Up to 10,000 bph (280 mth)**

***Complimented by Comparison.***

# MYSiLO

## Drive over convenience. Belt conveyor capacity.

### INCLINE LENGTH

Standard incline section length is 64" (163 cm). On non portable units a 64" (163 cm) incline section extension may be requested, which provides up to 20" (51 cm) of additional discharge height.



### DISCHARGE SPOUT

The large discharge outlet features a full 16" x 21" (41 x 53 cm) rectangular outlet. The spout is fully adjustable and sits a full 3'-4" (.91 m-1.0 m) above the ground.

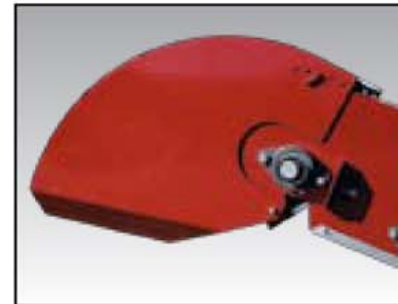

### BELT DESIGN

The 24" (61 cm) belt features a PVC crescent pattern with slider bed backing, stainless steel belt splice and a 42 1/2" (107 cm) hopper shield dump area.



### SPRING LOADED BELT TAKE UP

The spring loaded belt take up enables greater drive efficiency and lower belt tension requirements. Includes snub pulley for slip-free operation.



### BELT ALIGNMENT GUIDE

Exclusive belt alignment guide rollers maintain proper belt tracking for optimum belt life (Patent Pending).



### DRIVE-OVER

The full 7' x 10' (2 x 3 m) wide area provides a convenient, safe design for high capacity dumping. The system is engineered so the ramps and dumping area are fully integrated into a single unit. The low profile drive over only requires a minimal 5-1/2" (14 cm) clearance.



### EXCLUSIVE WALK ACROSS PLATFORM AND HANDRAIL

The walk across platform provides safety and accessibility when unloading semi trailers and other grain hauling equipment.



### UNDERCARRIAGE

The system rotates using a hydraulic cylinder for lift as standard equipment.



### DRIVE OPTIONS



Hydraulic Drive  
(shown with optional valve kit)



Electric Drive



PTO Drive

# Drive Over Belt Conveyor

## Key Benefits

- Low drive-over clearance requires only 5-1/2" (14 cm) clearance.
- Extra wide 24" (61 cm) belt.
- Smooth transition from horizontal to incline.
- Optional greater discharge height (non portable units only).
- Higher capacity with lower belt speeds.
- Drive choices.
- Receive from side dump wagons, as well as bottom dump and rear dump vehicles.
- S-type drive on return belt for greater drive efficiency and lower belt tension requirements. Includes snub pulley to give greater wrap at drive pulley for slip-free operation.
- Spring loaded belt take-up for lower operating belt tensions.
- Guide roller assembly to keep belt tracking properly.
- Removable hitch tube.
- Self cleaning wing type tail pulley.

## General Specifications

### INCLINED TROUGH:

### DRIVE:

### UNDERCARRIAGE:

### OPERATING BELT SPEED:

### CAPACITY:

### HORSEPOWER REQUIRED:

- Flat bottom, troughed edges, 10 gauge, 20 degree inclined angle.
- S-Drive on crescent face of belt w/spring loaded take-up, lagged drive pulley. Conveniently located under the incline section.
- Rotating arm design using a hydraulic cylinder.
- 600-800 feet (183-244 m) per minute.
- Up to 10,000 bushels per hour (280 mth).
- 10 HP electric. Hydraulic drive capacity minimum 20 gal./min. (15 HP electric for non portable drive over belt with the 64" extended incline section)

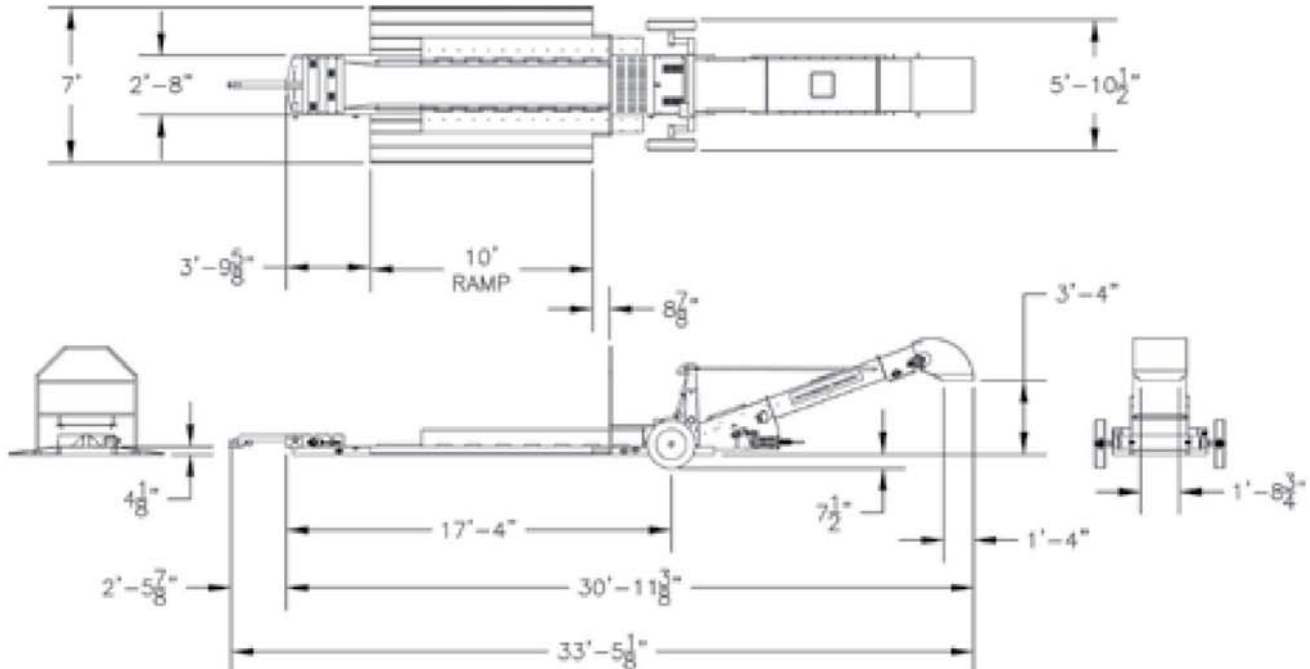

# MYSILO

Organize Sanayi Bölgesi 1.Cadde No:52/B

Aksaray/TÜRKİYE

Tel: +90.382.266 22 45(6 hat)

Fax: +90.382.266 22 52

www.mysilo.com

e-mail: mysilo@mysilo.com